

# 150W Electric Bicycle Charger

## HT45F5Q-5, HT45F5QC-5/-6

### Characteristics

- Complied with the new standard
- Socket design for main control MCU, easy to replace
- Provides relevant development platform to speed up development
- Battery reverse connection, short-circuit, temperature detection, fan-locked protection
- Includes a CAN Bus communication controller, RS-485 communication or single interface frame communication

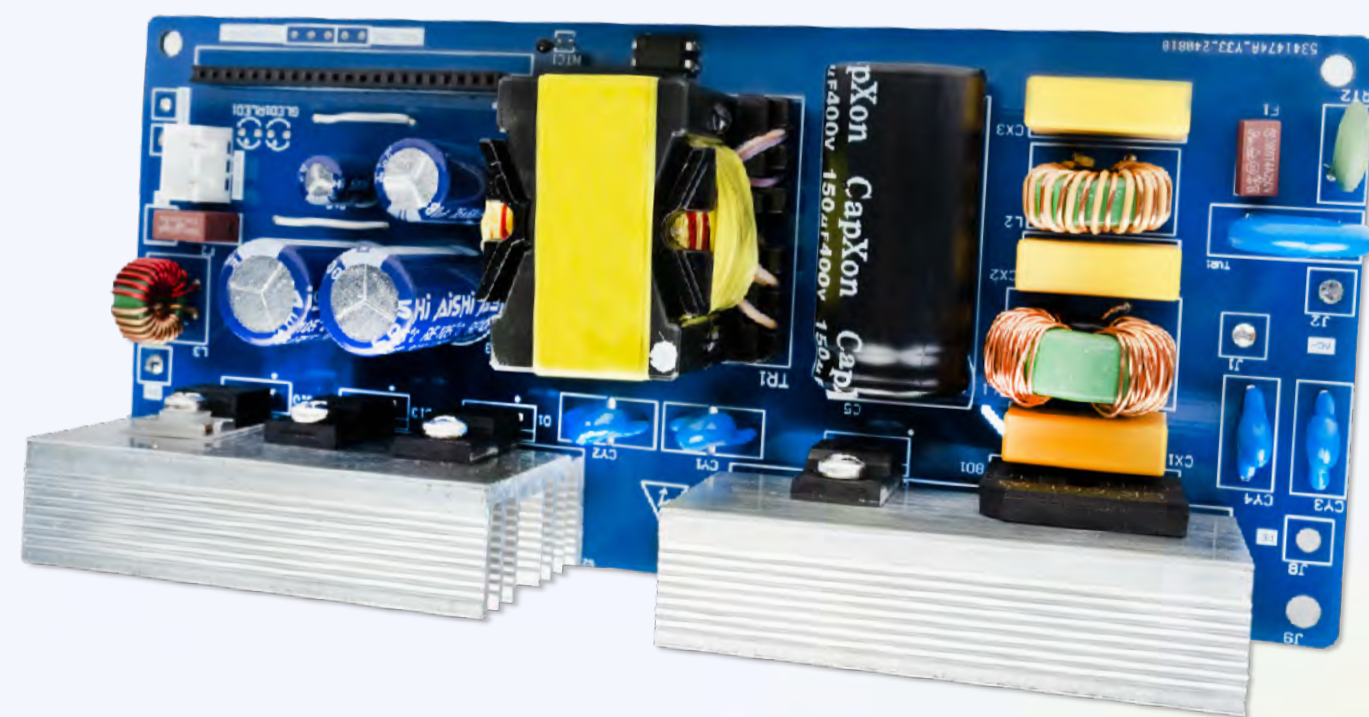
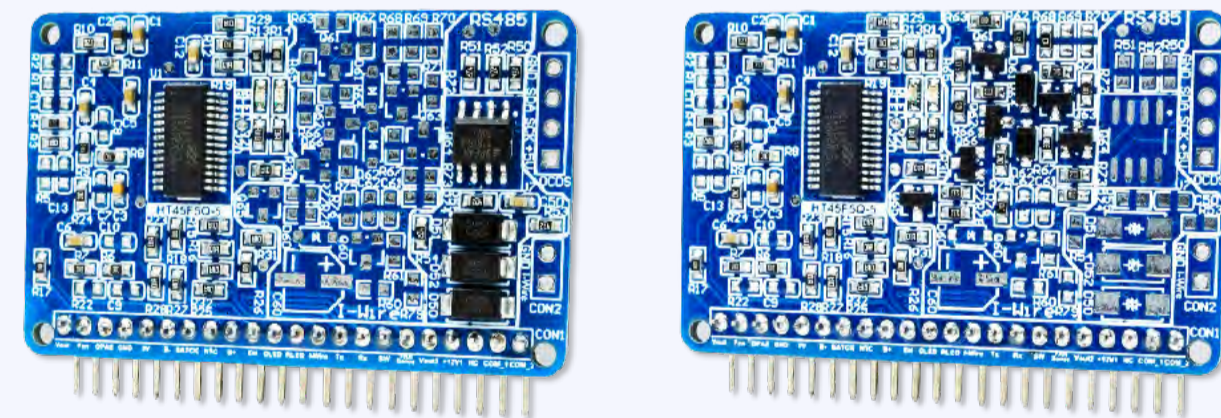

### Block Diagram

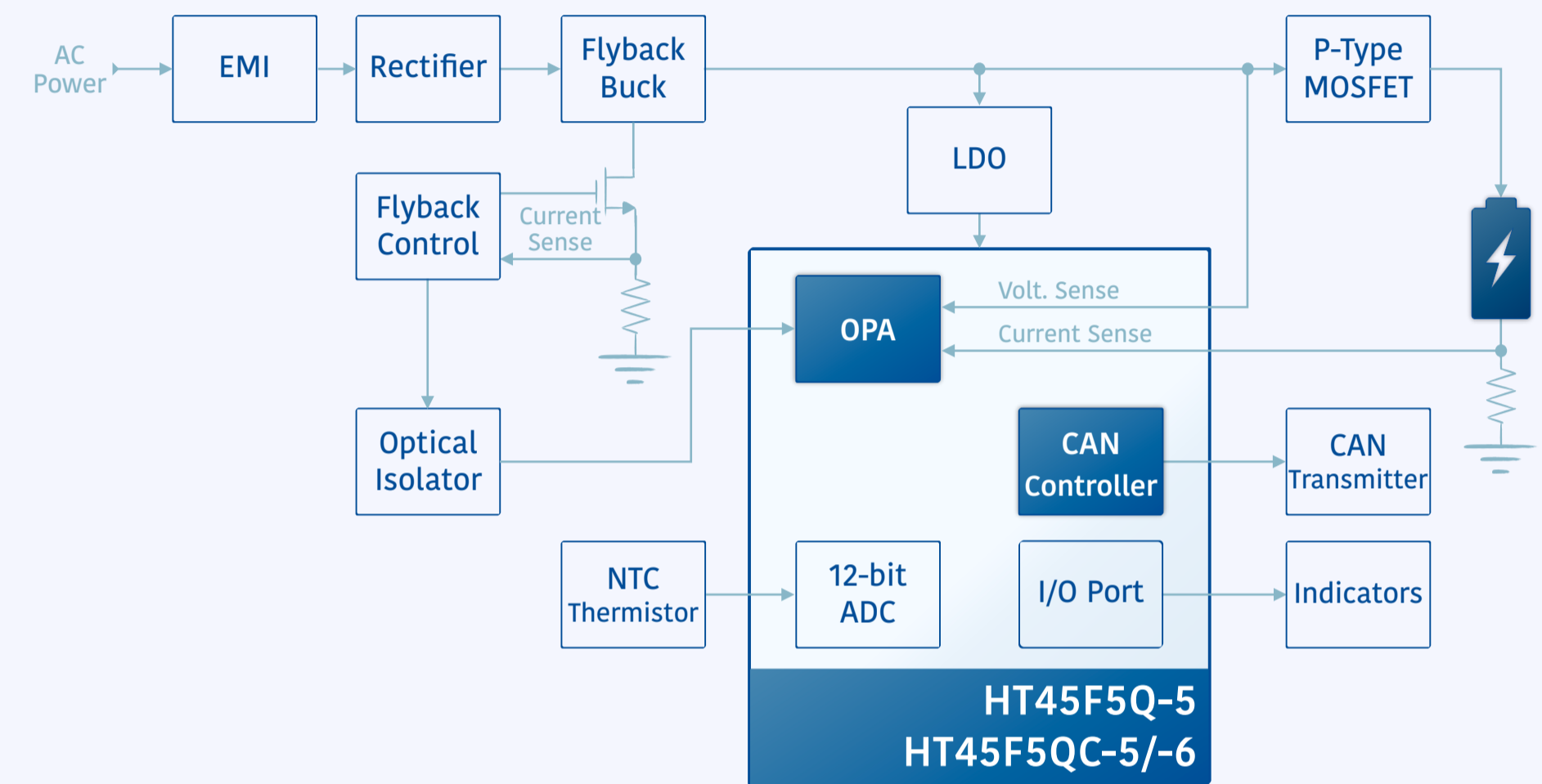

### Applications

Electric bicycles, electric (light) motorcycles, etc.

