

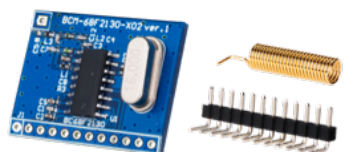

1 配件清單

1. 並列式RF無線接收模組 (BCM-68F2130-X02) x 1
2. 彈簧天線 (433.92MHz Antenna) x 1
3. 90°排針12-pin x 1



2 部件說明

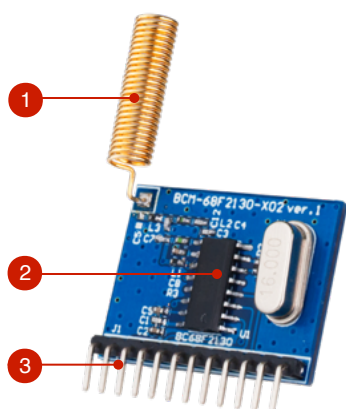

- 1 Spring antenna
- 2 BC68F2130
- 3 Pin header

3 腳位順序



Pin #	Pin Name	Description
1	GND	GND
2	VDD	VDD
3	VDDRF	VDDRF
4	OCSDA	OCSDA
5	OCDSCK	OCDSCK
6	TX_LED	PB4
7	KEY1	PA4
8	KEY2	PA5
9	KEY3	PA3
10	KEY4	PA1
11	Reserved1	PB5
12	N.C.	N.C.

4 系列產品說明與注意事項

採自訂發射訊號協定，需搭配其中一種模組使用：

- 評估板：BCE-GENTX-X01
 - 並列式 433MHz RF接收模組：BCM-68F2420-C01
 - 串列式 433MHz RF接收模組：BCM-2401-C03
- 請另自行購買，詳情請參考附錄一：產品系統圖

5 功能簡述

1. 本產品工作頻率為433.92MHz
2. 主控 MCU BC68F2130 內部已寫入程式，使用者無須再自行撰寫
3. RF傳輸封包內容請參考附錄二：HT OOK demo board package format

6 請先焊接天線與排針

注意：天線請垂直地面並遠離金屬

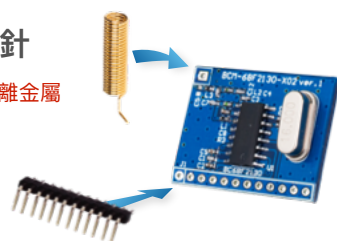

7 將本模組插入評估板(需另購)上方插槽

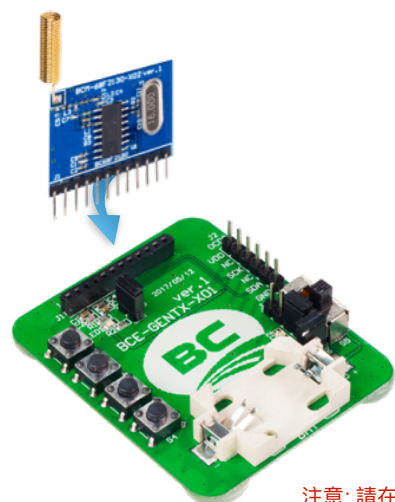

注意：請在電源關閉時進行操作

8 裝入電池

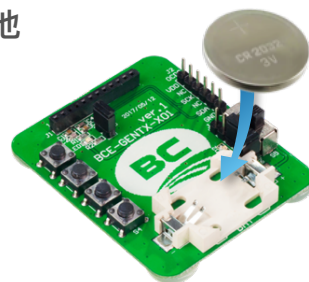

9 開啟電源

電源指示LED2將亮起

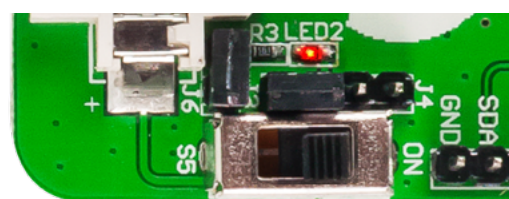

on

10 信號傳輸與指示

評估板按下任一按鍵，即可發射對應的RF信號，指示發射訊號的LED1燈將亮起，每次按壓按鍵RF無線發射端至少發射兩次封包，鬆開按鍵後便停止發射，LED1燈熄滅



注意：按鍵按壓請至少達40ms，以免系統無法識別

11 省電模式

鬆開按鍵後，訊號發送停止，LED燈熄滅，自動進入省電模式



12 方塊圖

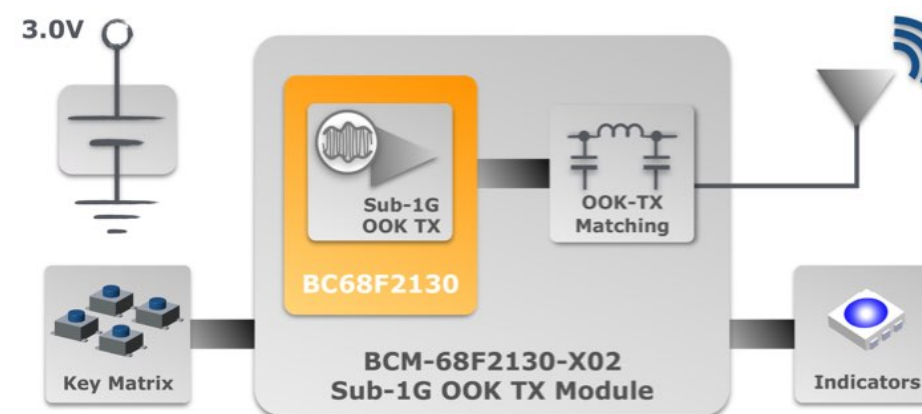

13 電路圖

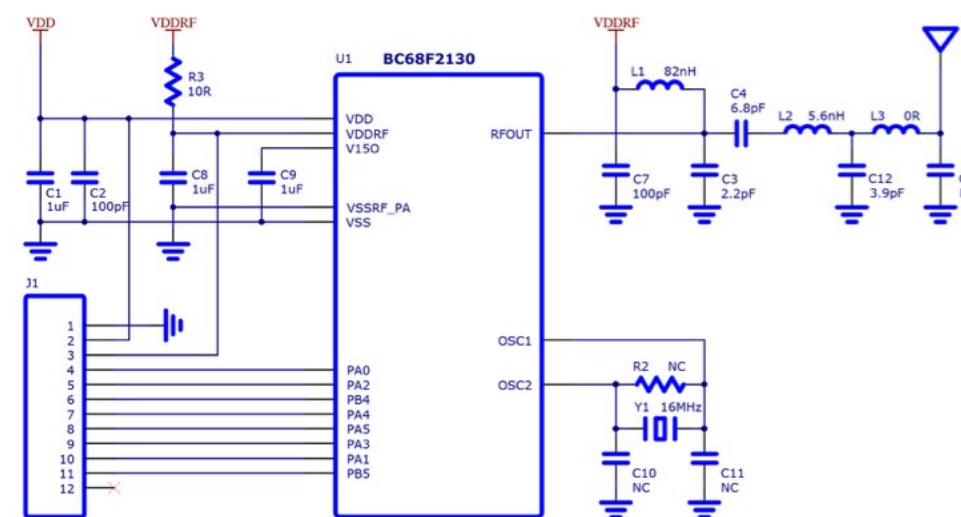



16 附錄一：產品系統圖

本產品需與評估板(BCE-GENTX-X01)配套使用：

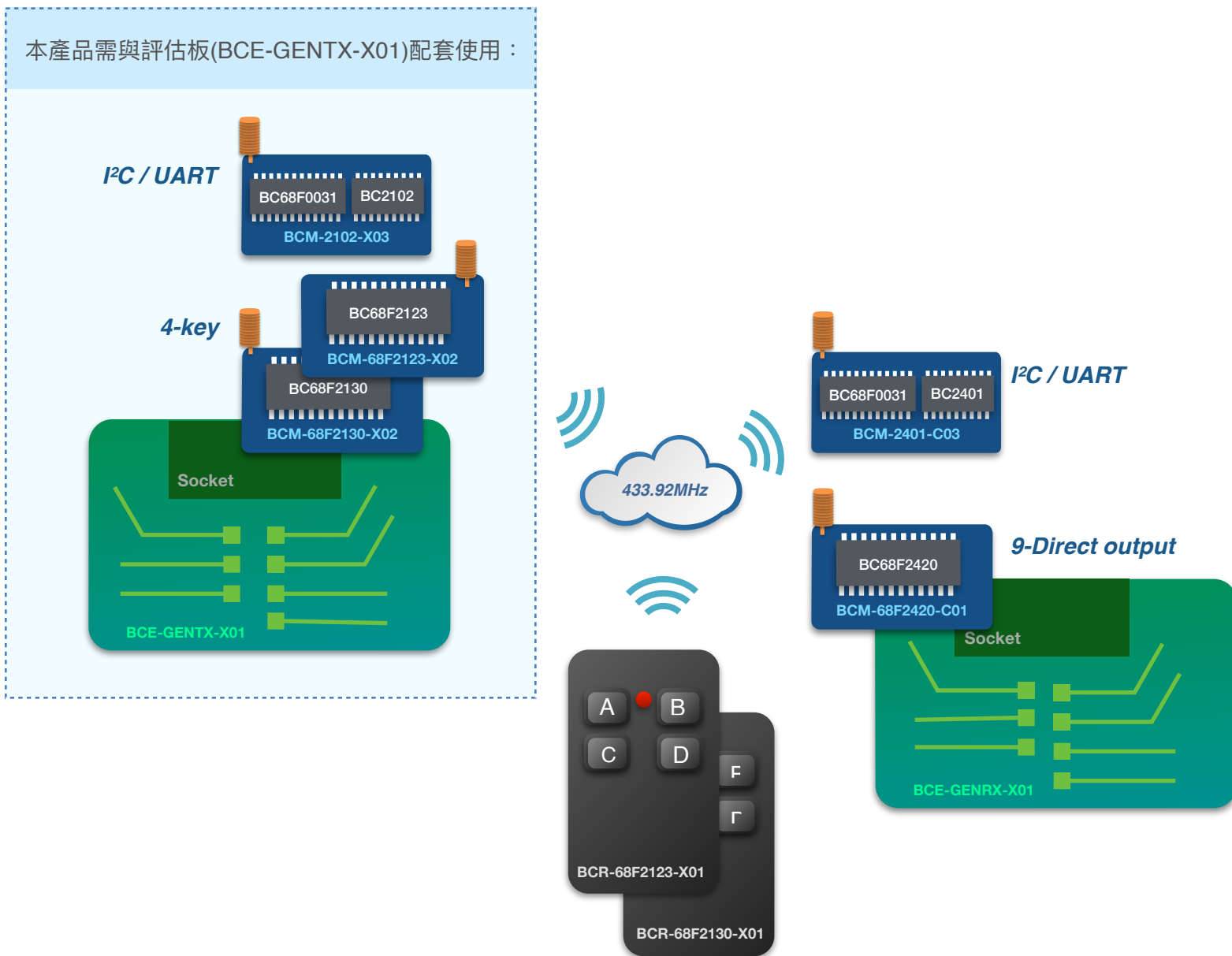

Hyper link

BC68F0031

BC68F2123

BC68F2130

BC68F2420

BC2401

BC2102

17 附錄二：HT OOK demo board package format

The “code word” is a group of code bits used in OOK wireless communication. This document describes the code word format used in HT OOK demo boards. A code word consists of leading code, start code, address, data, CRC and end code. Each fields are composed with several symbols. The symbol rate is set as 5Kbps. Each symbol (λ) in table below is 200us.

A. Leading Code + Start code

Leading code: Repeating 1 λ high and 1 λ low for 8 times. Start code: 4 λ high + 2 λ low



B. Address, data & CRC

Each bit is composed with 4 symbols. The format for bit “0” and “1” are shown below:

Bit “0” → 1 λ high + 3 λ low Bit “1” : 3 λ high + 1 λ low



For TX demo boards / remote controllers, their addresses are pre-programmed in the MCU program ROM. Users do not need to specify the address.

For RX demo boards, they have to be paired with a TX first before being used. The pairing process allows the RX recognize the TX and memorize TX’s address in its non-volatile memory.

$$CRC = X^8 + X^5 + X^4 + 1$$

Below shows the data when K1~K4 is pressed down

	D7	D6	D5	D4	D3	D2	D1	D0
K1	0	0	0	0	0	0	0	1
K2	0	0	0	0	0	0	1	0
K3	0	0	0	0	0	1	0	0
K4	0	0	0	0	1	0	0	0

C. End code: 2 λ high + 2 λ low

End code is used to separate the sequent two code words.

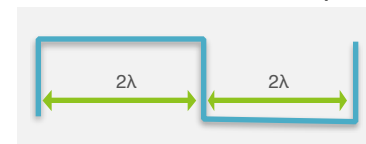

The code word format is like:

	Leading	Start	Address	Data	CRC	END
length	16 λ	6 λ	4 λ /bit*24bit	4 λ /bit*8bit	4 λ /bit x 8bit	4 λ

The total length for a code word is 200us x (16+6+96+32+32+4) = 37.2ms